

# Operation Note

## 11941C Close-Field Probe



Part NO. CK-11941-90008  
Printed in USA Feb 2013

# Notice

---

## Product Transition

Under the authorization of Agilent Technologies, Cokeva, Inc. is offering the 11941C as a direct replacement for the Agilent 11941A. The 11941C provides the functionality and reliability you expect.

## Contacting Cokeva Sales and Service Office

For more information, please contact us at:

Cokeva, Inc.  
9000 Foothills Blvd, Roseville, CA 95747 USA  
[www.cokeva.com](http://www.cokeva.com)  
[sales@cokeva.com](mailto:sales@cokeva.com)  
Tel: +1 916.462.6000

Business hours: Mon – Fri | 8:00 AM - 4:30 PM (Pacific Standard Time)

In any correspondence or telephone conversation, please refer to your instrument by its model number and full serial number.

## **Certification**

Cokeva, Inc. certifies that this product met its published specifications at the time of shipment from the factory.

---

## **Warranty**

This Cokeva, Inc. product is warranted against defects in material and workmanship for a period of one year from date of shipment or for the length of a purchased warranty extension if applicable. During the warranty period, Cokeva, Inc. will, at its option, either repair or replace products which prove to be defective.

For warranty service or repair, this product must be returned to Cokeva, Inc. Buyer shall prepay shipping charges to Cokeva, Inc. and Cokeva, Inc. shall pay shipping charges to return the product to Buyer. Buyer shall pay all shipping charges, duties, and taxes for products returned to Cokeva, Inc. from another country.

Cokeva, Inc. warrants that its software and firmware designated by Cokeva, Inc. for use with an instrument will execute its programming instructions when properly installed on that instrument. Cokeva, Inc. does not warrant that the operation of the instrument, or software, or firmware will be uninterrupted or error-free.

### **LIMITATION OF WARRANTY**

The foregoing warranty shall not apply to defects resulting from improper or inadequate maintenance or calibration by Buyer or by vendors not approved by Cokeva, Buyer-supplied software or interfacing, unauthorized modification or misuse, operation outside of the environmental specifications for the product, or improper site preparation or maintenance.

NO OTHER WARRANTY IS EXPRESSED OR IMPLIED. COKEVA SPECIFICALLY DISCLAIMS THE IMPLIED WARRANTIES OF MERCHANTABILITY AND FITNESS FOR A PARTICULAR PURPOSE.

### **EXCLUSIVE REMEDIES**

THE REMEDIES PROVIDED HEREIN ARE BUYER'S SOLE AND EXCLUSIVE REMEDIES. COKEVA, INC. SHALL NOT BE LIABLE FOR ANY DIRECT, INDIRECT, SPECIAL, INCIDENTAL, OR CONSEQUENTIAL DAMAGES, WHETHER BASED ON CONTRACT, TORT, OR ANY OTHER LEGAL THEORY.

---

## **Assistance**

*For any assistance, contact the Cokeva, Inc. Sales and Service Office at +1 916.543.7600 between 8:00 AM – 4:30 PM (PST), Mon – Fri.*

# Content

---

1-1.	General Information. ....	1
1-2.	Description . ....	1
1-4.	Initial Inspection. ....	1
2-1.	Specifications. ....	2
3-1.	Operation . ....	2
3-2.	Theory of Operation. ....	2
3-4.	Antenna Factors . ....	2
3-7.	Power Density and Electric Field Calculations. ....	4
3-9.	Localized Field Source. ....	4
 3-11.	Test Setups. ....	5
3-16.	Measurement Techniques . ....	8
4-1.	Operation Verification. ....	10
4-5.	Output Impedance Measurement Test. ....	10
4-9.	Insertion Loss Measurement Test . ....	13
5-1.	SMA Rotary Joint Installation Procedure. ....	16

## SAFETY SYMBOLS

The following safety symbols are used throughout this manual and in the instrument. Familiarize yourself with each of the symbols and its meaning before operating this instrument.



Instruction manual symbol. The instrument will be marked with this symbol when it is necessary for the user to refer to the instruction manual in order to protect the instrument against damage. Location of pertinent information within the manual is indicated by use of this symbol in the table of contents.



Indicates dangerous voltages are present. Be extremely careful.



The CAUTION sign denotes a hazard. It calls attention to a procedure which, if not correctly performed or adhered to, could result in damage to or destruction of the instrument. Do not proceed beyond a CAUTION sign until the indicated conditions are fully understood and met.



The WARNING sign denotes a hazard. It calls attention to a procedure which, if not correctly performed or adhered to, could result in injury or loss of life. Do not proceed beyond a WARNING sign until the indicated conditions are fully understood and met.

## 1-1. GENERAL INFORMATION

### 1-2. Description

1-3. The Cokeva 11941C Close-Field Probe is a hand-held electromagnetic field sensor designed to make repeatable, calibrated magnetic field measurements from 9 kHz to 30 MHz. It is optimized for the location and measurement of sources of electromagnetic interference (EMI) in electronic equipment. The Cokeva 11941C can also be used as a localized magnetic field source when operated in conjunction with an appropriate signal generator, thereby allowing circuit-board-level susceptibility testing of instruments.

Shipment includes:

ITEM	DESCRIPTION	QUANTITY
11941C	Close field probe, hand held, 9kHz – 30 MHz	1
9320-6720	China RoHS Addendum for Accessories	1
1250-1250	Adapter Coaxial straight Male-N Female-SM	1
1250-1700	Adapter Coaxial straight Male-BNC Female-SMA	1
8120-4811	Cable Assembly – Coaxial	1
CK-11941-90008	Operation Note	1

### 1-4. Initial Inspection

1-5. If the shipment contents are incomplete or damaged, notify the Cokeva office. If the shipping container is damaged, or the cushioning material shows signs of stress, notify the carrier as well as the Cokeva office. Keep the shipping materials for the carrier's inspection. The Cokeva office will arrange for repair or replacement without waiting for a claim settlement.

1-6. See Paragraph 4-1 for Operation Verification.

## 2-1. SPECIFICATIONS

2-2. Specifications for the Cokeva 11941C are listed in table 1. An asterisk (\*) placed after an entry indicates a supplemental characteristic. Supplemental characteristics are not specifications, but are characteristics included as additional information for the user.

2-3. Figure 1 illustrates the characteristic frequency response for the Cokeva 11941C Close-Field Probe. See section 3-4, Antenna Factors, for additional information.

## 3-1. OPERATION

### 3-2. Theory of Operation

3-3. The Cokeva 11941C is a balanced magnetic-field sensor that provides an output voltage proportional to the strength of the magnetic field at its tip. Radiated magnetic fields couple directly to the Cokeva 11941C and produce an output signal; radiated electric fields also couple to the Cokeva 11941C, but do not produce an output voltage due to the construction of the probe. The Cokeva 11941C uses a dual-loop sensor and a balun to reject electrically-coupled signals. These loops are illustrated in Figure 2, which shows the probe with its non-removable protective tip cover cut away for clarity.

The probe does not rectify the input signal; it provides both amplitude and frequency information. It is ideally suited for use with a spectrum analyzer. The Cokeva 11941C circuitry is passive and therefore only contributes thermal noise to any measurement system. Inspect the probe tip for damage before using, and do not use the probe if the protective tip cover is missing or damaged.

### 3-4. Antenna Factors

3-5. The specific antenna factors of each Cokeva 11941C are measured to within  $\pm 2$  dB at five frequencies: 9 kHz, 100 kHz, 1 MHz, 10 MHz, and 30 MHz. This calibration information is listed on the bottom cover of each probe. The antenna factors are given in the units of  $\text{dB}(\frac{\mu\text{A}}{\text{m}}/\mu\text{V})$ . To calculate the magnetic field strength in  $\text{dB}(\frac{\mu\text{A}}{\text{m}})$  at a specific frequency, add the amplitude of the measured voltage in  $\text{dB}(\mu\text{V})$  (as indicated on the spectrum analyzer) to the antenna factor for that specific frequency. To compensate for cable losses and preamplifier gains, add the losses and subtract the gains (in dB). Refer to the following equation:

$$\bar{H} \text{ -Field Strength } \left( \text{dB} \frac{\mu\text{A}}{\text{m}} \right) = V_{SA} + AF + K$$

where

$V_{SA}$  = voltage in  $\text{dB}\mu\text{V}$  measured on analyzer

$AF$  = HP 11941A Antenna Factor in  $\text{dB} \left( \text{dB} \frac{\mu\text{A}/\text{m}}{\mu\text{V}} \right)$

$K$  = loss or gain in dB between 11941C and spectrum analyzer  
(Positive value if loss, negative value if gain.)

Table 1. Cokeva 11941C Specifications

Antenna Factor:	Measured for each unit at 0.009, 0.100, 1, 10, and 30 MHz to within $\pm 2$ dB in a 377-ohm field impedance. See Figure 1 for characteristic antenna factor data.
Temperature Range:*	0°C to +40°C: $<\pm 1$ dB (Operating) -10°C to +65°C (Storage)
Frequency Range:	9 kHz-30 MHz
Connector:	SMA, replaceable barrel
Maximum Input Power	0.5 watts
Maximum voltage at tip: *	1 kV (dc + peak ac)
Weight:*	Net: 0.10 kg (0.22 lbs) Shipping: 0.56 kg (1.2 lbs)

DIMENSIONS IN MILLIMETERS AND (INCHES)

\*supplemental characteristic

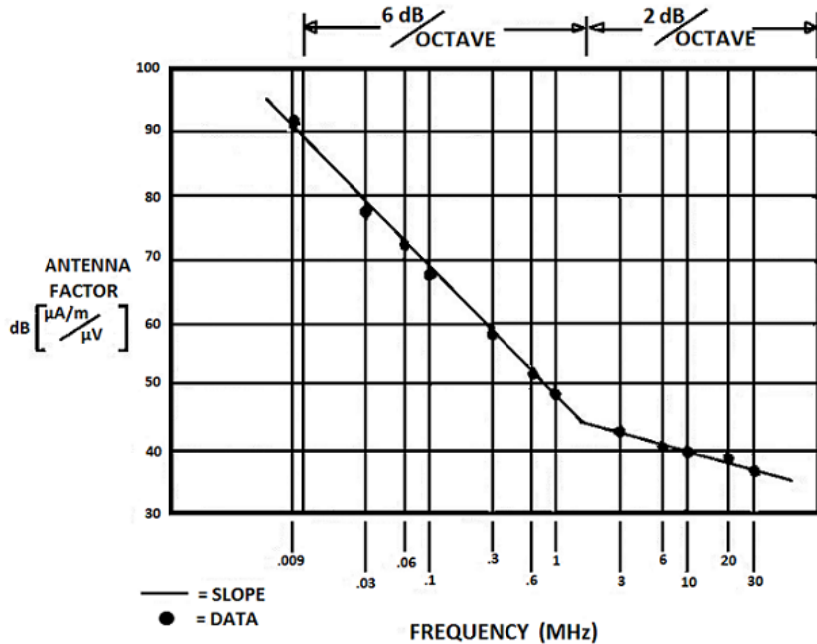

Figure 1. Cokeva 11941C Characteristic Antenna Factors, 9 kHz-30 MHz



3-6. Use the data included in Figure 1 for interpolating antenna factors between the five calibration frequencies included in the probe's calibration table.

### 3-7. Power Density and Electric Field Calculations

3-8. The Cokeva 11941C measures magnetic field strength. An estimate of the magnitude of the associated electric field can be made if a field impedance is assumed. An example is given below using a 377-ohm field impedance. Radiated power density can also be estimated, assuming that the fields are in phase and that the field impedance is 377 ohms.

$$\begin{aligned} \text{E-Field Strength} \left( \text{dB} \frac{\mu\text{V}}{\text{m}} \right) &= V_{SA} + AF + K + 20 \log(377) \\ &= V_{SA} + AF + K + 51.5 \end{aligned}$$

$$\text{Power Density} \left( \text{dB} \frac{\text{mW}}{\text{cm}^2} \right) = V_{SA} + AF + K - 104.3$$

where

$V_{SA}$  = voltage in dB  $\mu\text{V}$  measured on analyzer

$AF$  = 11941C Antenna Factor in  $\text{dB} \left( \frac{\mu\text{A}/\text{m}}{\mu\text{V}} \right)$

$K$  = loss or gain in dB between 11941C and spectrum analyzer

(Positive value if loss, negative value if gain.)

EXAMPLE:

At 10 MHz, measured  $V_{SA} = 65.3 \text{ dB}\mu\text{V}$ . Let  $K = 0$  and  $AF = 39 \text{ dB} \left( \frac{\mu\text{A}/\text{m}}{\mu\text{V}} \right)$

then

$$E \left( \text{dB} \frac{\mu\text{V}}{\text{m}} \right) = 65.3 + 39 + 51.5 = 155.8 \text{ dB}\mu\text{V}/\text{m} = 61.7 \text{ V}/\text{m}$$

$$S \left( \text{dB} \frac{\text{mW}}{\text{cm}^2} \right) = 65.3 + 39 - 104.3 = 0 \text{ dB} \frac{\text{mW}}{\text{cm}^2} = 1 \frac{\text{mW}}{\text{cm}^2}$$

### 3-9. Localized Field Source

3-10. The probe can also be used as a localized magnetic field source for locating susceptible components on a circuit board. It is a reciprocal device; that is, a current fed into the probe will generate a magnetic field at the dual-loop sensor. The specified antenna factors cannot be used to estimate the magnitude of the output field. Table 2 lists characteristic field strengths developed 1 mm (0.040 in.) away from the probe tip, using an incident power of 0 dBm into 50 ohms.

**CAUTION**

Power applied to the probe must not exceed the maximum input power listed in table 1 or damage to the probe will result.

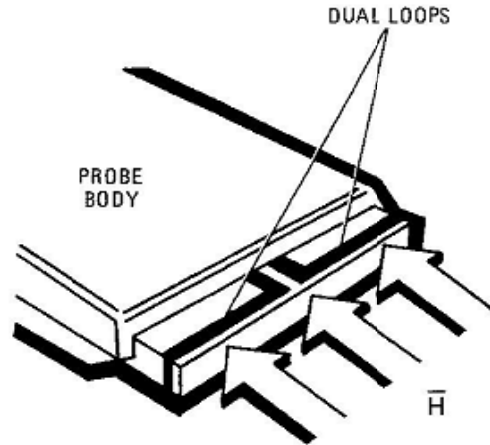

Figure 2. Magnetic Field Orientation for Maximum Coupling

Table 2. Characteristic Magnetic Field Strengths

Frequency (MHz)	Input Power (into 50Ω)	Magnetic Field Strength ( $\bar{H}$ ), dB ( $\mu\text{A/m}$ )
0.009	0 dBm	122
0.100	0 dBm	120
1	0 dBm	120
10	0 dBm	110
30	0 dBm	101

**3-11. Test Setups**

3-12. The Cokeva 11941C operates as either a localized magnetic field probe or localized magnetic field source. The following paragraphs describe different applications and test setups for the probe. Table 3 lists the recommended test setup equipment used in these examples. Any equipment that satisfies the critical specifications listed in table 3 may be substituted for the recommended equipment. When used as a probe, be sure to add the antenna factors and cable losses to the signal levels indicated on the spectrum analyzer. If a preamplifier is used to increase measurement sensitivity, subtract its gain from the displayed signal level.

**WARNING**

The dielectric material on the tip of the probe has a characteristic breakdown voltage of 1 kV. To prevent damage to the probe and/or personal injury to the user, the probe should not be used where a potential of over 1 kV is available.

3-13. Localized Emissions Test Setup: Figure 3 illustrates a typical configuration used for localizing EMI emissions. See section 3-16 for proper probe placement.

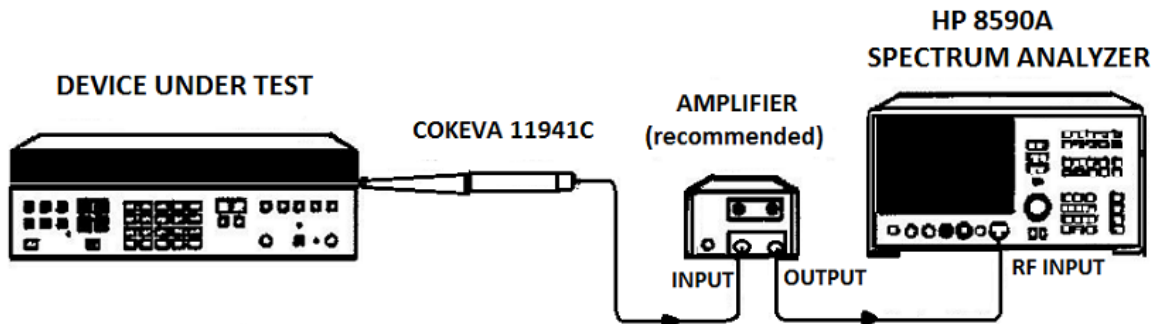

Figure 3. Localized Emissions Test Setup

Table 3. Recommended Test Setup Equipment

Instrument	Critical Specifications	Recommended Model
Spectrum Analyzer	Frequency Range: 9 kHz - 30 MHz	HP 8562A (100 Hz – 2.9 GHz) HP 8566B (100 Hz – 300 GHz) HP 8567A (10 kHz – 1.5 GHz) HP 8568B (100 Hz – 1.5 GHz) HP 8590A (10 kHz – 1.5 GHz) Option H51, Close – Field EMC Feature Set HP 71100A (100 Hz – 2.9 GHz) Option 002
Tracking Generator	Frequency Range: 9 kHz - 30 MHz	HP 8444A (0.5 – 1500 MHz) Option 059, For use with HP 8566B HP 8567A, and HP 8568B HP 70300A (100 Hz – 2.9 GHz) For use with HP 71100A
Signal Generator	Frequency Range: 9 kHz - 30 MHz	HP 8660C (10 kHz – 2.6 GHz) HP 8662A (10 kHz – 1280 MHz)
Preamplifier*	Frequency Range: 9 kHz - 30 MHz RF Gain: >20 dB	HP 8447A (9 kHz – 50 MHz) Option H64 HP 8447F (9 kHz – 1.3 GHz) Option H64
* An HP 85685A RF Preselector may be substituted if an HP 8566B, HP 8567A, or HP 8568B spectrum analyzer is used.		

3-14. Stimulus-Response Test Setup: The relative shielding effectiveness of various enclosures and shielded structures can be tested using stimulus-response techniques. See Figure 4. The tracking generator output signal radiates from an antenna placed inside the enclosure under test, while the probe and spectrum analyzer provide frequency and relative amplitude information. See section 3-16 for proper probe placement.

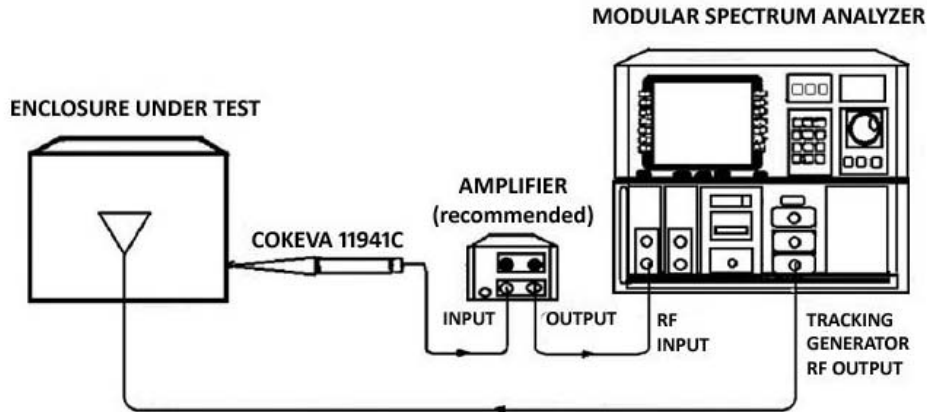

Figure 4. Stimulus-Response Test Setup

3-15. Localized Susceptibility Test Setup: Used as a field source, the probe provides a magnetic field for susceptibility testing of electronic devices. The distance between the probe tip and the Device Under Test (DUT) should be less than 1 cm (0.394 in.). As the probe is moved closer to the DUT, the absolute magnetic field strength applied to the DUT approaches the calculated value produced at the probe tip. For broadband susceptibility testing, use the probe with a swept or tracking source. See Figure 5 for an example of the basic localized susceptibility test setup.

**CAUTION**

Power applied to the probe must not exceed the maximum input power listed in table 1 or damage to the probe will result.

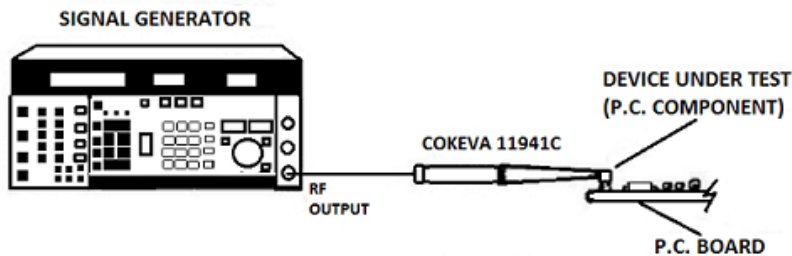

Figure 5. Localized Susceptibility Test Setup

### 3-16. Measurement Techniques

3-17. The Cokeva 11941C measures the magnetic field strength at the center of its sense loop, not at the probe tip. Figure 6 details the relationship between the probe tip cover and the probe loop centerline. The probe is designed to be held very close to potential radiating points. The plane of the probe tip loops must be perpendicular to the radiating magnetic field as illustrated in Figure 2. For example, if the seam of an enclosure is being tested for EMI, hold the probe as illustrated in Figure 7. When measuring the radiation from a coaxial cable, position the probe as in Figure 8, which shows the sense loops. The side of the probe with the antenna factor calibration label should be facing away from the cable being measured. Do not use the probe if the protective tip cover is missing or damaged.

3-18. The probe may be used as a source in susceptibility testing, as described in section 3-9 and also in paragraph 3-15. In this application, hold the probe within 1 cm (0.394 in.) of the electronic circuit component being tested.

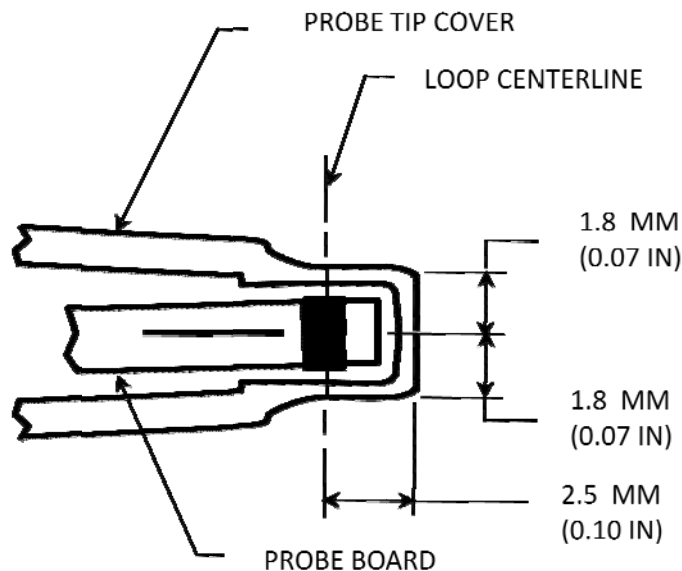

Figure 6. Probe Tip Detail

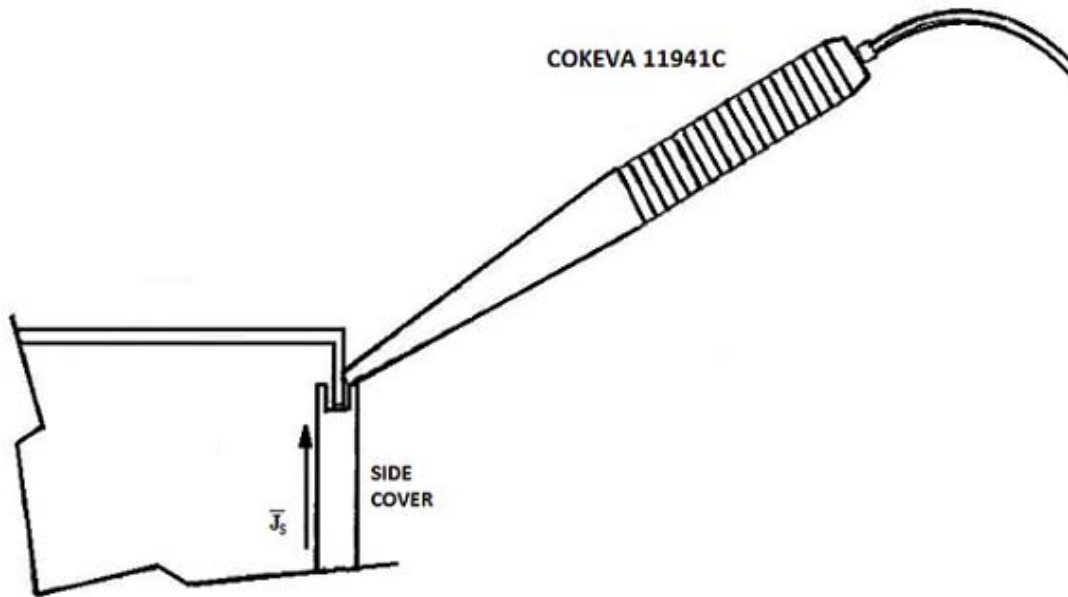

Figure 7. Testing an Enclosure Seam

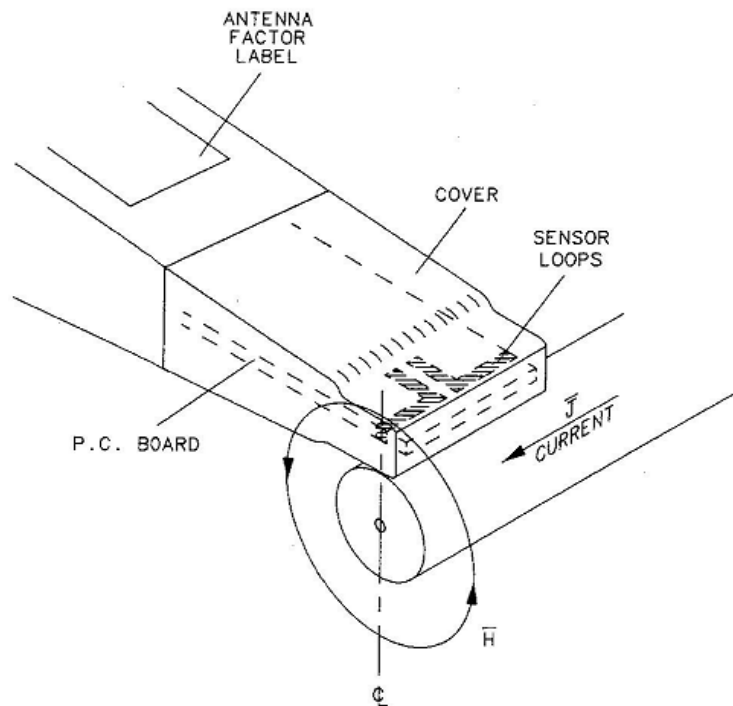

Figure 8. Testing a Coaxial Cable

**4-1. OPERATION VERIFICATION**

4-2. Operation Verification for the Cokeva 11941C consists of two tests: an output impedance measurement test, and an insertion loss measurement test. Each test is relative and designed to detect damage in specific parts of the circuitry. These tests are not designed to verify antenna-factor calibration, which requires a calibrated magnetic field.

4-3. Probes that fail these tests may still detect electromagnetic radiation. In this case, the probe circuitry no longer rejects electric field coupling and the antenna factors listed on the unit are no longer valid.

4-4. In the test procedures, instrument softkeys will be represented by *shadow* print. Softkeys are keys whose function is defined by text on the display.

**4-5. Output Impedance Measurement Test**

Description

This test measures the impedance of the Cokeva 11941C at the SMA port, over a frequency range of 100 KHz to 1 MHz, to detect any damage in the output circuitry. Any equipment that satisfies the following critical specifications for the test setup may be substituted for the recommended equipment:

- Frequency Range. . . . . 100 KHz to 1 MHz
- Test Port Match. . . . . >15 dB Return Loss

Recommended Equipment

- Network Analyzer. . . . . HP 3577A
- S-Parameter Test Set . . . . . HP 35677A

Adapters:

- Type N (m) to APC 3.5 (m) . . . . . HP 1250-1743

Accessories:

- 50 ohm Load, APC 3.5 (f) . . . . . HP 909D
- Coaxial Short, APC 35 (f) . . . . . HP 1250-1769
- Open, APC 3.5 (f) . . . . . HP 1250-1767

**Procedure**

1. Connect the equipment as shown in Figure 9. Allow the HP 3577A 60 minutes of warm-up time.

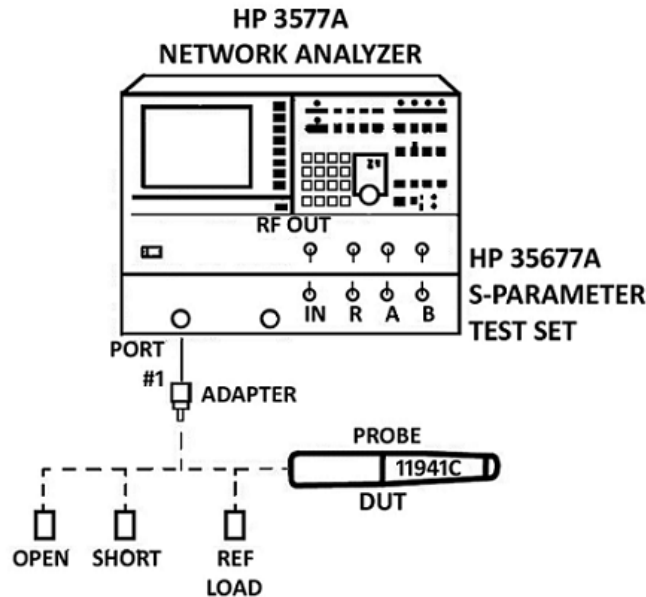

Figure 9. Output Impedance Test Setup

2. Set the HP 3577A controls as follows:

```

TRACE 1
INPUT .....S11
DISPLAY FUNCTION .....POLAR
SMITH CHART ..... ON
FULL SCALE ..... 1 UNIT

SWEEP TYPE ..... Lin. Freq. Sweep
SWEEP MODE ..... Cont.
START FREQ ..... 100 kHz
STOP FREQ ..... 1 MHz

AMPTD ..... +15 dBm
    
```

3. Perform the full one-port calibration by pressing the Measr Cal key and *One Port Full Cal*. Follow the directions on the display.
4. Connect the probe to Port One of the HP 35677A. The impedance display should appear as shown in Figure 10. At 100 kHz the measured impedance should approximate that of a short circuit; at 1 MHz the probe should measure inductively, with a maximum normalized impedance value of  $j0.50$ . The most common failure mode for this test would be an open in the input circuitry, in which case the impedance display would appear as shown in Figure 11.



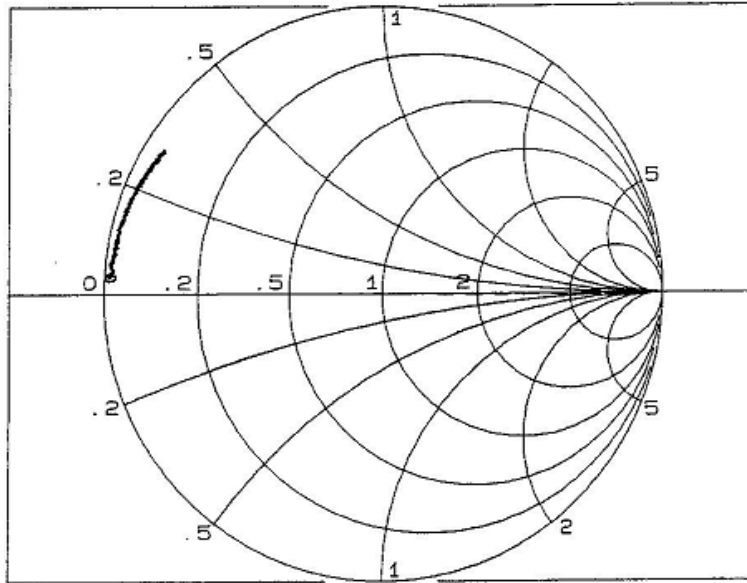

Figure 10. Impedance Plot of Functional Cokeva 11941C  
(100 kHz to 1 MHz)

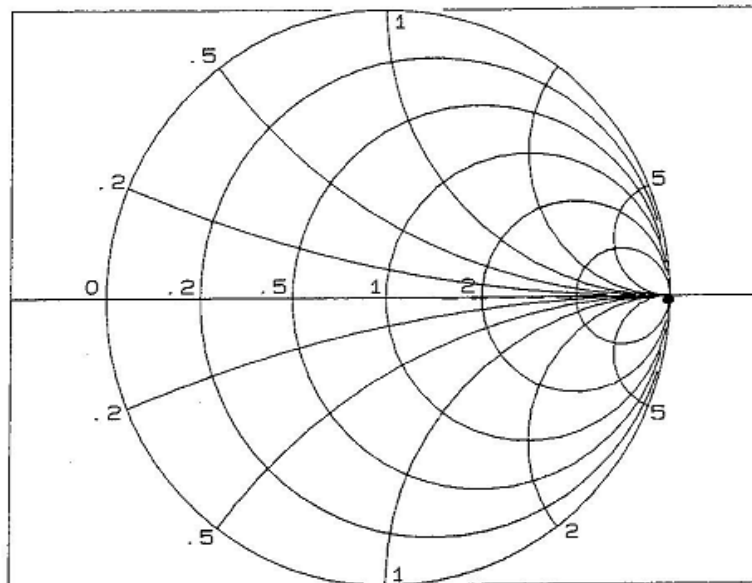

Figure 11. Impedance Plot of Cokeva 11941C with Open Circuit  
(100 kHz to 1 MHz)

**4-9. Insertion Loss Measurement Test**

Description

The insertion loss test is a relative indicator of damage in the input circuitry. Using a second Cokeva 11941C as a magnetic field source, this test selectively injects a magnetic field into each loop of the Cokeva 11941C being tested. Damage is indicated by differences in the measured output voltages. It is important to orient the two probes properly as shown in Figures 12 through 15. To facilitate testing, the source probe should be fixed in place, the tip flush with the work surface (preferably wooden). This can be accomplished with clamps or tape, which should be no closer than 50.8 mm (2 in.) to the source tip. Other test equipment may be substituted if it meets or exceeds the critical specifications for the instruments listed below. Throughout the test procedure, the probe being tested will be referred to as the DUT (Device Under Test).

Recommended Equipment

Network Analyzer .....HP 3577A  
 S-Parameter Test Set .....HP 35677A  
 Field-Source .....Cokeva 11941C

Adapters:

Type N (m) to APC 3.5 (m) (2 required) .....HP 1250-1743

Cables:

SMA (m) to SMA (m), 2m (2 required) .....HP 8120-4811

**Procedure**

1. Connect the equipment as shown in Figure 12. Allow the HP 3577A 60 minutes of warm-up time.

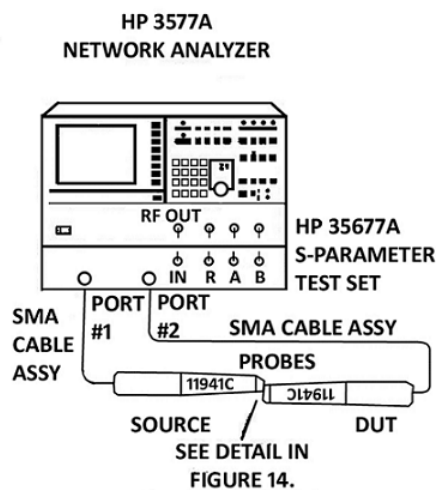

Figure 12. Insertion Loss Test Setup

2. Set the HP 3577A as follows:

```

INST PRESET
TRACE 1
INPUT ..... S21
DISPLAY FUNCTION ..... Log Mag
REF LEVEL ..... -30 dBm
SCALE ..... 5 dB/Div
REF POS ..... 100 %

SWEEP TYPE ..... Log Freq. Sweep
SWEEP MODE ..... Cont.
START FREQ ..... 100 kHz
STOP FREQ ..... 30 MHz

AMPTD ..... +15 dBm
    
```

3. Physically align the probes as shown in Figures 13 and 14. The identification label of the DUT should face upward. This alignment illuminates one of the sense loops of the DUT with a magnetic field.

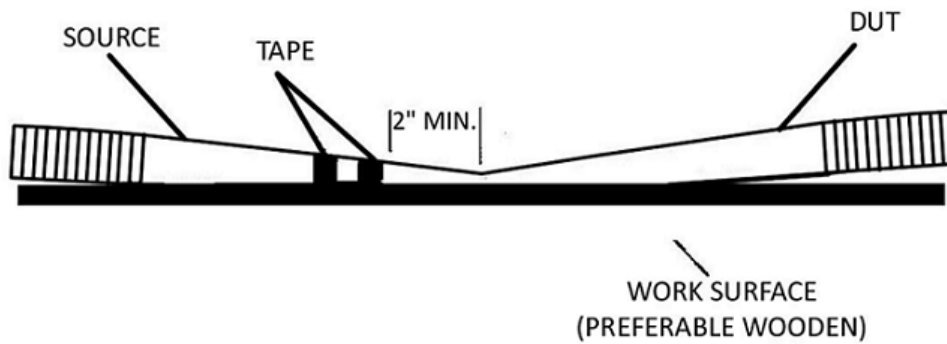

Figure 13. Probe Orientation for Insertion Loss Test

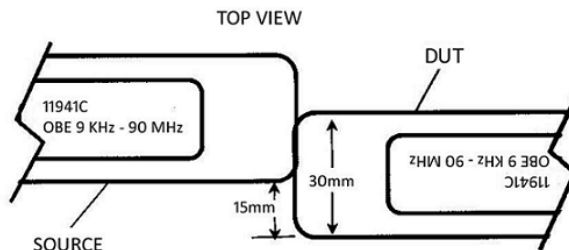

Figure 14. Detail of Probe Orientation for Insertion Loss Test (Measurement of Loop #1)

4. Press the STORE DATA key, then *Store & Display*.
5. Realign the DUT as shown in Figure 15. The calibration label of the DUT should face upward. This position illuminates the second sense loop of the DUT with the same magnetic field intensity as the first loop.
6. Press the STORE DATA key and *Store Reg D1*. Then press the INPUT key and *Data Reg*.

The two displayed traces will typically be  $\leq 3$  dB apart for properly functioning probes, and  $> 6$  dB apart for damaged probes. If your measurements are repeatedly yielding results between 3 dB and 6 dB, then the test setup should be checked.

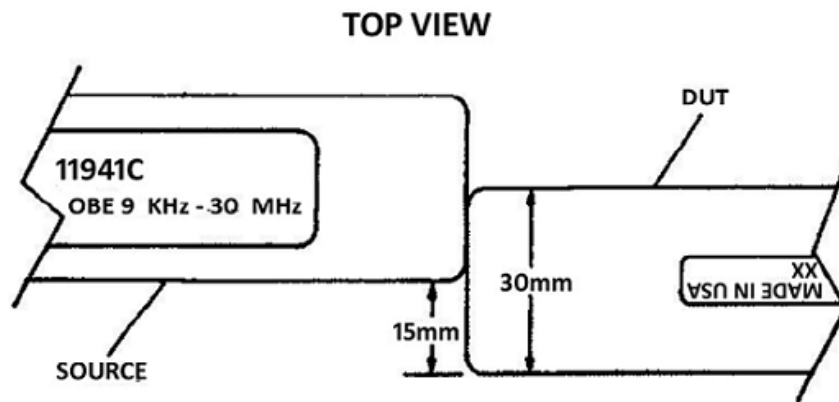

Figure 15. Detail of Probe Orientation for Insertion Loss Test  
(Measurement of Loop #2)

### 5-1. SMA ROTARY JOINT INSTALLATION PROCEDURE

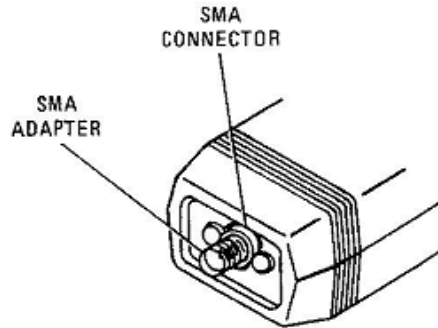

Figure 16. SMA Adapter Location

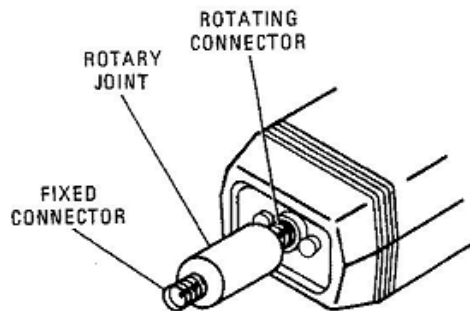

Figure 17. RF Rotary Joint Mounted on Probe

1. Use a 7/32-inch wrench to remove the old SMA adapter (see Figure 16). Turn the adapter counterclockwise as viewed from the rear end of the probe.
2. The SMA Rotary Joint has an SMA connector located at each end. One connector rotates with respect to the body of the rotary joint. The other connector is fixed to the body. Cover two or three end threads of the rotating end connector with a small amount of Loctite 222<sup>®</sup>.
3. Screw the rotating end of the rotary joint clockwise into the probe's SMA connector (see Figure 17).
4. Using a 9/32-inch torque wrench, tighten the rotary joint to 24 inch-pounds.
5. When attaching a cable to the rotary joint, hold the rotary joint by hand to keep the connector from turning.

For Cokeva Internal Reference Only

Cokeva Part Number CK-11941-90008

Printed in USA

February 2013